

MegaPulse series Impulse Tester

Instruction Manual

COMPLIANCE
WEST *USA*

Dear Customer:

Congratulations! Compliance West USA is proud to present you with your MegaPulse Impulse Tester. Your instrument features a groundbreaking logic-controlled circuit design and ergonomic front panel and represents the latest in high voltage impulse testing.

To fully appreciate all the features of your new instrument, we suggest that you take a few moments to review this manual. Compliance West USA stands by your instrument with a full one-year warranty. If the need arises, please don't hesitate to call on us.

Thank you for your trust and confidence.

Table of Contents

- An Introduction to Impulse Testing with the MegaPulse series tester 1
 - Safety Precautions..... 1
 - Test Personnel..... 1
 - Testing Area..... 1
 - Safety Techniques..... 2
 - Using the MegaPulse Impulse Tester..... 2
- Introduction and Specifications 5
 - Introduction 5
 - Figure 1..... 5
 - Specifications 5
 - Table 1. MegaPulse series specifications..... 6
- Operation 7
 - Setting up your Tester 7
 - AC Line Voltage Requirements 7
 - Selection of a Suitable Power Cord 7
 - Fuse Replacement 7
 - Front and Rear Panel Features 7
 - Figure 2. Controls, Indicators, Connectors – MegaPulse series Front Panel 8
 - Table 2. Controls, Indicators, Connectors – MegaPulse series Front Panel 9
 - Figure 3. Controls, Indicators, Connectors – MegaPulse series Rear Panel 10
 - Table 3. Control, Indicators, Connectors – MegaPulse series Rear Panel 11
 - Figure 4. Controls, Indicators, Connectors – MegaPulse series Breakdown
Detection..... 12
 - Initial Checkout Procedure..... 14
 - Testing..... 15
 - TestMinder Operation 16
 - EN60335 Pulse Trains 16
 - Breakdown Detection Circuit Option..... 16
 - Sensitivity setting using known good and known bad samples 16
 - Approximate Sensitivity Setting using the supplied 50 ohm resistor 16
 - Defib-5 Checkout and Operation 17
 - Use of Measurement Terminals Y1 and Y2..... 17
 - Verification of Measurement Circuit Operation 17
 - Testing with the Defib-5 17
- Technical Assistance 21
- Maintenance and Calibration..... 23
 - Introduction..... 23
 - Service Information..... 23
 - General Maintenance 23
 - Interior Access 23
 - Calibration Access..... 23
 - Cleaning 24
 - Performance Test 24
 - Calibration Procedure 25
 - Voltage Calibration Adjustment 25
 - Figures 4-9 27

Section 1

An Introduction to Impulse Testing with the MegaPulse series tester

The impulse test is designed to simulate impulse surges which occur in everyday life due to nearby lightning strikes, switching transients, and other high-frequency faults on the power distribution network. Impulse testing is the fundamental method for empirical verification of the adequacy of insulation. Other methods of ensuring adequate insulation (AC or DC Dielectric Withstand testing, measurement of over-surface creepage, through-air clearance, or distance-through-insulation) are all extrapolated from the results of impulse testing. The impulse test is performed to ensure that the insulation in question will be able to function properly when subjected to similar impulse surges in the field.

Safety Precautions

The impulse withstand test can generate voltages in excess of 7000 V peak at potentially lethal current levels. Currents of as little as 5 mA at 120 volts can cause death; the MegaPulse can deliver currents of more than 100 Amps peak for a very short time duration. The potential for serious injury or death exists and personnel should be aware when they conduct this test.

Test Personnel

Personnel require special training to conduct the impulse test. They should understand electrical fundamentals clearly, and be aware that high voltage is adept and creative at completing a path to ground. Instructions should include a warning against any metal jewelry. Operators should not allow others in the testing area, especially when tests are being conducted. Organization is to be stressed. The operator should keep the area free of unused leads and equipment.

Testing Area

The area used for conducting the dielectric withstand test should be as remote as possible from normal production line activities. Only personnel actually conducting the test should be allowed in the area, and it should be taped or roped off to preclude casual entry by other employees. In addition, the area should be marked "WARNING - HIGH VOLTAGE TESTING" or the equivalent to warn others of the nature of the testing taking place.

The bench being used should be non-conductive, and any exposed metal parts should be tied together and grounded. If a conductive surface must be used, it should be grounded.

Because of sparking during an impulse test failure, it is not safe to conduct impulse testing in combustible atmospheres.

It is imperative that a good ground be provided to the MegaPulse tester. Before connecting the equipment, ensure that the building wiring provides a low-resistance ground. If the MegaPulse tester is used on a high-resistance grounding circuit, dangerous high voltages may be present to the operator. In addition, the power to the Testing Area should be provided with an easily reached shutoff switch which can be actuated by personnel outside the Area if needed.

Safety Techniques

The high voltage circuit of the MegaPulse can be shut off at any time by turning OFF the rear power switch. Note that there are residual voltages inside the equipment that may take up to 5 minutes to bleed off to safe levels.

The MegaPulse tester is provided with a **VOLTAGE ADJUST** knob on the front panel. This should always be adjusted fully counterclockwise to the minimum position at the start of testing. In addition, this knob should be adjusted back to the minimum position at the completion of all testing.

The MegaPulse tester is provided with a **CHARGE** switch that is in the unarmed "Standby" setting when the tester is first turned ON. When the yellow **CHARGE** button is lit, the tester will not provide high voltage until the **CHARGE** Button and the **TRIGGER** Button have been pressed in order. To prevent inadvertent operation, the operator should be instructed not to press the **CHARGE** Button until the test is ready.

The MegaPulse tester has been designed for one-touch operation with the right hand. If possible, it should be set up to the left and in front of the equipment under test. The equipment under test should be connected to the MegaPulse tester and then left alone by the operator. After the operator is clear of the Tester and the equipment under test, the operator should turn the rear-panel power switch to ON, press the **CHARGE** Button, adjust the voltage to the desired level (as displayed on the front panel meter), then press the **TRIGGER** Button, with his right hand. This will allow the greatest separation between the operator and the test being conducted.

The MegaPulse tester is designed to bleed the high voltage away after the test has concluded. In order to ensure that any voltage present in the equipment being tested has been completely bled away, the operator should not unplug the equipment under test from the MegaPulse until the front panel meter reads a safe level (40 volts or less is generally considered a safe level). Pressing the **TRIGGER** button before disconnecting main power (or turning the equipment off) will ensure that the internal capacitors are discharged as much as possible.

Using the MegaPulse Impulse Tester

The impulse withstand test involves high voltage and caution should be exercised when using the Tester. The **RETURN** lead is referenced to building ground when properly connected. However, both the **OUTPUT** and **RETURN** leads must always be treated as Hazardous whenever the power switch of the MegaPulse is in the ON position.

The MegaPulse impulse tester generates the impulse waveform only; it does not determine Passing or Failing results. It is Operator's responsibility to monitor the output waveform and determine Passing or Failing results. In monitoring the impulse waveform, consider the following points:

The Impulse waveform is high voltage, and high frequency (short duration). Always ensure that the measuring instrument (usually an oscilloscope with a high-voltage probe) is rated for the voltage involved, and that the frequency response of the instrument and probe are capable of measuring the output waveform of the MegaPulse Impulse Tester. A measuring instrument or probe with a low frequency response will result in erroneous readings that could be mis-read.

Pressing the **POLARITY** switch on the front panel can change the polarity of the output waveform. The polarity is Normal when the **NOR** indicator is lit. In this case, the High Voltage will appear on the **OUTPUT** as a positive pulse relative to the **RETURN** jack. When the polarity switch is in the Reverse position (**REV** indicator is lit), the High voltage will appear on the **OUTPUT** as a negative pulse relative to the **RETURN** jack. The polarity switch only operates when the **CHARGE LED** is lit, i.e. the output is not charged.

Note that the Voltage meter may indicate that some residual voltage is present on the main storage capacitor, even when the tester is first turned ON. This is due to inherent charging of the internal capacitors. Pressing the **TRIGGER** switch will discharge the capacitors (be sure not to touch the output and return leads when pressing the trigger switch).

Note that the peak amplitude of the measured output waveform is proportional to the voltage that is read on the front panel of the MegaPulse, but it will always be somewhat lower. This is because the meter on the MegaPulse is measuring the voltage on the main impulse storage capacitor (C1 in Figure 1). This voltage will intentionally dissipate to some extent before reaching the output leads. Therefore, it is important to measure the peak amplitude of the output waveform, and adjust the output of the MegaPulse accordingly.

Determination of Passing and Failing results can prove difficult. To obtain the most accurate results, it is generally necessary to perform multiple impulse tests on a few different test samples (that have adequate insulation to pass the impulse test). Take note of the impulse waveshape, amplitude, and duration. Also note how much variance there is in the waveshape from test to test. Also (if possible), perform impulse testing on some test samples that are known to have inadequate (or damaged) insulation. Take note of the impulse waveshape, amplitude, and duration, when an insulation breakdown occurs.

It is possible to perform simultaneous testing on multiple test samples. In order to accurately determine Passing and Failing test results, it is generally necessary to perform multiple tests with a single (failing) sample connected along with multiple “passing” samples. Make sure that it is always possible to distinguish a group of tests samples that are all “passing” from a group with a single “failing” sample.

Section 2

Introduction and Specifications

Introduction

This manual contains complete operating, maintenance and calibration instructions for the Compliance West USA MegaPulse series Impulse Tester.

- In case of trouble, the test can be immediately terminated at any time by turning the rear-panel power switch to the OFF position.
- Before the test can commence, the unit must be armed by pressing the **CHARGE** Button. The test will not begin until the **TRIGGER** Button is pushed.
- Operator instructions are printed on the rear panel for quick reference.
- Voltage is discharged by a resistor bank within the MegaPulse tester upon test completion. Discharge progress is shown on the front panel meter.

Specifications

Specifications for each individual model in the MegaPulse series are listed in Table 1. Component designations referenced in Table 1 are as shown in Figure 1.

Your Tester is warranted for a period of one year upon shipment of the instrument to the original purchaser.

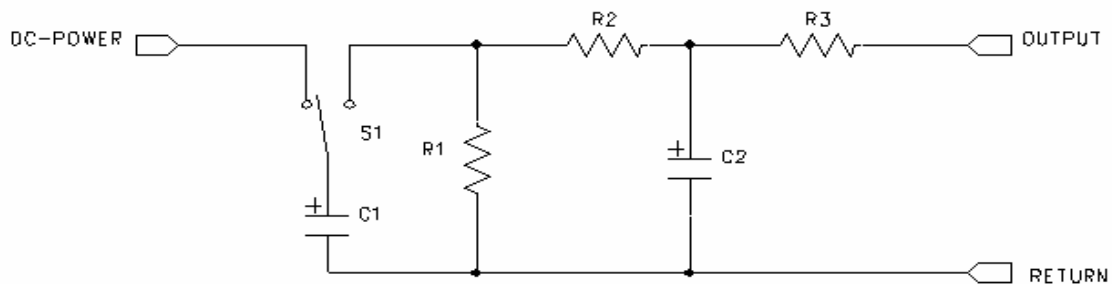

Figure 1.

Model	Waveform*	Max. Voltage	C1	R1	R2	C2	R3
10x700-2.5	10 x 700/6 x 300 uS	2500V	20 uF	50 Ohms	15 Ohms	0.2 uF	25 Ohms
10x700-7	10 x 700/6 x 300 uS	7000V	20 uF	50 Ohms	15 Ohms	0.2 uF	25 Ohms
1.2x50-2.5	1.2 x 50/1 x 20 uS	2500V	1 uF	76 Ohms	13 Ohms	0.033 uF	25 Ohms
1.2x50-7	1.2 x 50/1 x 20 uS	7000V	1 uF	76 Ohms	13 Ohms	0.033 uF	25 Ohms
1.2x50-12 12 Ω Fast Charge ∂	1.2 x 50/1 x 20uS	12300V	2.75 uF	40 Ohms	7 Ohms	0.05uF	0 Ohms
1.2x50-12.3-1	1.2x50uSec 500 ohms	12,300	0.5uF	147 Ohms	328 Ohms	1 nF	253 Ohms
10x1000s-1	10 x 1000/10 x 1000 uS	1000V					
10x360s-1	10 x 360/10 x0360 uS	1000V					
2x10s-2.5	2 x 10/2 x 10uS	2500V					
Defib-5	20 x 2200/50 x 800 uS	5000V	32 uF (1)	100 Ohms	50 Ohms	None (open)	0 Ohms
Antenna Surge	Not defined	10000V	1 nF	-	1 kOhm	-	-
AXVI1-2.5, -7	1.2 x 50/0 x 7 uS	2500V, 7000V	0.25 uF	234 Ohms	62 Ohms	7800 pF	0 Ohms
AXVI2-2.5, -7	1.2 x 50/0 x 7 uS	2500V, 7000V	0.25 uF	234 Ohms	45 Ohms	7800 pF	0 Ohms
AXVI3-2.5, -7	.7 x 40/0 x 4 uS	2500V, 7000V	0.25 uF	234 Ohms	27 Ohms	7800 pF	0 Ohms
AXVI4-2.5, -7	0 x 40/0 x 4 uS	2500V, 7000V	0.25 uF	234 Ohms	27 Ohms	None (open)	0 Ohms
AXVI5-2.5, -7	0 x 40/4 x 40 uS	2500V, 7000V	20 uF	3 Ohms	25 Ohms	3300 pF	0 Ohms
AXVI6-2.5, -7	.2 x 40/ 0 x 35 uS	2500V, 7000V	20 uF	3 Ohms	13 Ohms	3300 pF	0 Ohms
AXVI7-2.5, -7	.2 x 40/0 x 30 uS	2500V, 7000V	20 uF	3 Ohms	9 Ohms	3300 pF	0 Ohms
AXVI8-2.5, -7	.2 x 40/0 x 30 uS	2500V, 7000V	20 uF	3 Ohms	7 Ohms	3300 pF	0 Ohms
AXVI9-2.5, -7	.1 x 40/0 x 25 uS	2500V, 7000V	20 uF	3 Ohms	5 Ohms	3300 pF	0 Ohms
AXVI10-2.5, -7	.08 x 40/0 x 20 uS	2500V, 7000V	20 uF	3 Ohms	3 Ohms	3300 pF	0 Ohms

* Legend: A x B/C x D A= Voltage rise time B= Voltage duration C= Current rise time D= Current duration

Voltage rise time (A) is defined as follows (per ANSI/IEEE C62.41 and other standards): $t_{rise} = 1.67(t_{90} - t_{30})$, where t_{90} and t_{30} = the times of the 90% and 30% amplitude points on the leading edge of the waveform.

Voltage duration (B) is defined (per ANSI/IEEE C62.41 and other standards) as the time between virtual origin and the time of the 50% pint on the tail. The virtual origin is the point where a straight line between the 30% and 90% points on the leading edge of the waveform intersects the $V = 0$ line.

Current rise time (C) is defined as follows (per ANSI/IEEE C62.41 and other standards): $t_{rise} = 1.25(t_{90} - t_{10})$, where t_{90} and t_{10} = the times of the 90% and 10% amplitude points on the leading edge of the waveform.

Current duration (D) is defined (per ANSI/IEEE C62.41 and other standards) as the time between virtual origin and the time of the 50% pint on the tail. The virtual origin is the point where a straight line between the 10% and 90% points on the leading edge of the waveform intersects the $I = 0$ line.

∂ Indicates Models using Compliance West USA IEC 65 Switch.

Note 1: 32 uF capacitor in series with a 500uH inductor having a DC resistance no greater than 10 Ohms.

Common specifications:			
Meter Accuracy: 2500V output versions: ± 20 V 5000V, 7000V versions: ± 40 V All models: better than 1% of full-scale reading	Environmental: 15-40°C operating temperature 0-90% Relative Humidity, non-condensing	Electrical: Input Voltage: 120 V, 50-60 Hz Input Current: 1 -7 A (model specific)	Mechanical: Weight: Approx. 16-85 lbs. Dimensions: 11.25"W x 12"D x 5"H To 24"W x 20"D x 36"H

Table 1. MegaPulse series specifications

Section 3

Operation

This section describes how to set up and make measurements with your Tester. We recommend that you read the entire section carefully so that you can use all of the features of your Tester.

Setting up your Tester

Your Tester is shipped in a special protective container that should prevent damage to the instrument during shipping. Check the shipping order against the contents of the container and report any damage or short shipment to Compliance West USA. The container should include the following:

- The MegaPulse Impulse Tester
- Two high-voltage test leads
- An 18 AWG Line Power Cord
- This Instruction Manual

If reshipment of the instrument is necessary, please use the original shipping container. If the original shipping container is not available, be sure that adequate protection is provided to prevent damage during shipment. We recommend that the instrument be surrounded by at least two inches of shock-absorbing material on all sides of the container.

Remove the Tester from its container and place it on a test bench.

AC Line Voltage Requirements

AC line voltage requirements for your Tester are noted on the rear panel of the instrument. Do not connect the instrument to a different voltage source.

Selection of a Suitable Power Cord

The cord packaged with your MegaPulse Tester is for use in the United States. If another power cord must be used, the cord must be rated for the maximum current noted on the rear panel. It must also meet the requirements of IEC 227 or IEC 245, and mains cords that are certified or approved by any recognized national test house are regarded as meeting this requirement.

Fuse Replacement

There is a user-replaceable fuse (F1) located on the rear panel of the instrument. It is located behind a door in the Power Inlet-Power Switch-Fuse Holder device. The fuse rating is noted on the rear panel. Do not attempt to replace it with a fuse of any other rating.

Use the following procedure to replace the fuse F1:

1. Turn the power switch to the O or off position.
2. Unplug the instrument from the source of supply.
3. Remove the power inlet cord from the instrument.
4. Using a small screwdriver, pry open the fuse holder door.
5. Replace the fuse with a new one of the correct rating.
6. Replace the fuse holder door and power inlet cord.

Front and Rear Panel Features

Before using your Tester, take a few minutes to become familiar with the use of its controls, indicators and connectors. The front panel features of the MegaPulse are shown in Figure 2 and described in Table 2. The rear panel features of the MegaPulse are shown in Figure 3 and described in Table 3.

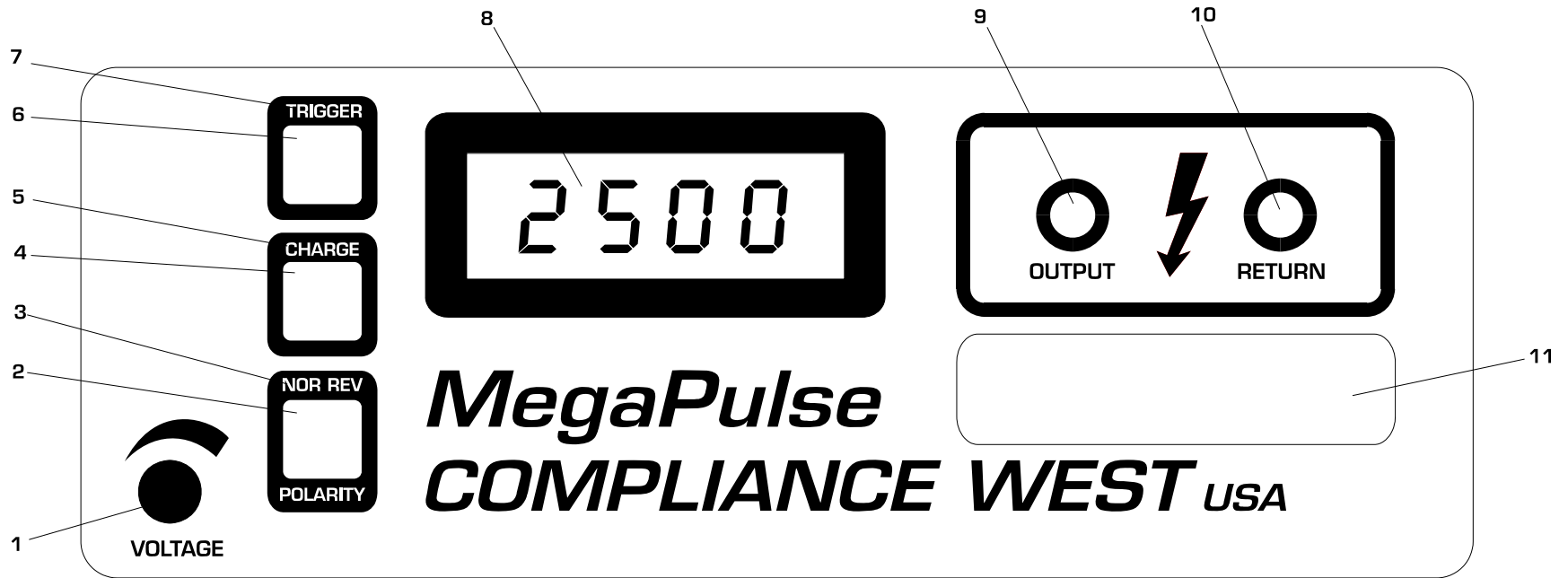

Figure 2. Controls, Indicators, Connectors – MegaPulse series Front Panel

ITEM	NAME	FUNCTION
1	VOLTAGE Adjust Knob	Turn Clockwise to increase the output voltage after the CHARGE button has been pressed. Turn the knob fully counterclockwise (lowest voltage setting) before the start of each test, and after the end of each test.
2	POLARITY switch	The polarity switch only operates when the CHARGE indicator is lit, i.e. the output is not charged. The polarity of the output waveform can be changed by pressing the POLARITY switch on the front panel. Press this switch to toggle the output polarity from Normal to Reverse. The polarity is Normal when the NOR indicator is lit. In this case, the High Voltage will appear on the OUTPUT as a positive pulse relative to the RETURN jack. When the polarity switch is in the Reverse position (REV indicator is lit), the High voltage will appear on the OUTPUT as a negative pulse relative to the RETURN jack.
3	NOR REV indicator	Indicates the state of the Output Polarity switch. NOR indicate Normal position, REV indicates Reverse position.
4	CHARGE switch	Press this switch to begin charging the impulse storage capacitor (C1 in Figure 1). The CHARGE indicator will turn off after the CHARGE switch is pressed, and the TRIGGER indicator will turn on. The voltage on the capacitor will appear on the LED Display, Item 8. This voltage will appear across the output leads when the TRIGGER switch is pressed. Note that the POLARITY switch is prevented from operating after the CHARGE switch has been pressed.
5	CHARGE indicator	This Yellow indicator is lit to show that pressing the CHARGE switch is the next logical step in a test sequence. Pressing the Charge switch causes the CHARGE indicator to go out.
6	TRIGGER switch	Press this switch (after pressing the CHARGE switch to charge the storage capacitor) to trigger the output impulse waveform. The impulse waveform will appear across the output leads.
7	TRIGGER indicator	This Red indicator is lit to show that pressing the TRIGGER switch is the next logical step in a test sequence. This indicator will turn on after the CHARGE switch is pressed, and will remain on until the TRIGGER switch is pressed. Pressing the TRIGGER switch causes the TRIGGER indicator to go out.
8	Voltage meter	Displays the output voltage set point. This voltage is the open-circuit peak voltage that will appear across the output leads when the trigger button is pressed. The voltage reading will increase from zero to the voltage set point when the Charge switch is pressed. Note that the Voltage meter may indicate that some residual voltage is present on the main storage capacitor, even when the tester is first turned ON. This is due to inherent charging of the internal capacitors. Pressing the TRIGGER switch will discharge the capacitors (be sure not to touch the output and return leads when pressing the trigger switch). Note that the peak amplitude of the measured output waveform is proportional to the voltage that is read of the front panel of the MegaPulse, but it will always be somewhat lower. This is because the meter on the MegaPulse is measuring the voltage on the main impulse storage capacitor (C1 in Figure 1). This voltage will intentionally dissipate to some extent before reaching the output leads. Therefore, it is important to measure the peak amplitude of the output waveform, and adjust the output of the MegaPulse accordingly.
9	OUTPUT jack	The impulse waveform appears on the OUTPUT jack, referenced to the RETURN jack. When the POLARITY switch is in the Normal position (NOR indicator is lit) the output will be a positive pulse. When the POLARITY switch is in the Reverse position (REV indicator is lit) the output will be a negative pulse.
10	RETURN jack	This is the return for the impulse waveform. This jack is referenced to the chassis of the MegaPulse, and is referenced to earth ground as long as the MegaPulse is properly grounded. Even though this jack is referenced to ground, it should be treated as hazardous whenever the MegaPulse is turned ON.
11	Model designation area	The specific MegaPulse model is indicated in this area. Optional metering/measurement test points may also be installed in this area.

Table 2. Controls, Indicators, Connectors – MegaPulse series Front Panel

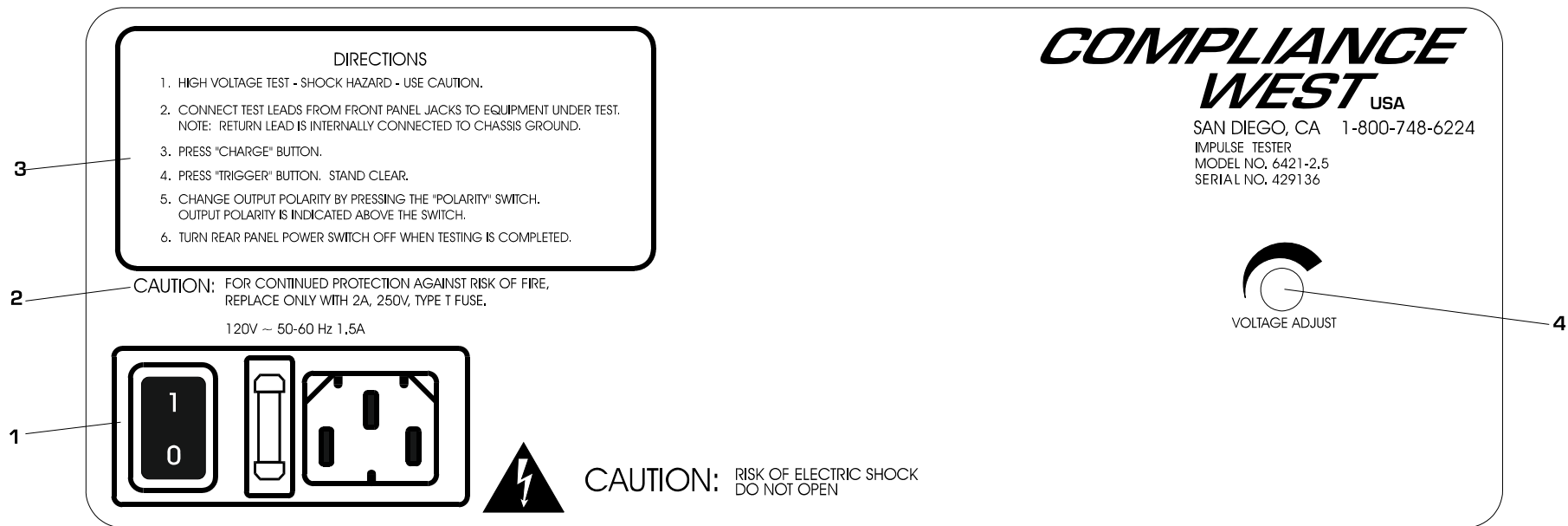

Figure 3. Controls, Indicators, Connectors – MegaPulse series Rear Panel

Table 3. Control, Indicators, Connectors – MegaPulse series Rear Panel

ITEM NO.	NAME	FUNCTION
1	Appliance Inlet / Fuse holder / Power Switch	Use supplied cordset to connect Tester to appropriate source of supply. Fuse holder provides access for Fuse replacement, and the Power Switch is used to turn the tester ON and OFF.
2	Fuse replacement warning / Rating of supply	Specifies replacement fuse and required supply voltage.
3	Directions	Provides directions for Tester operation to test personnel.
4	Voltage Adjust	Used to adjust the High Voltage output (as an alternative to the front panel Voltage Adjust knob). Turn Clockwise to increase the output voltage after the CHARGE button has been pressed. Turn the adjustment fully counterclockwise (lowest voltage setting) before the start of each test, and after the end of each test.



Figure 4. Controls, Indicators, Connectors – MegaPulse series Breakdown Detection

ITEM NO.	NAME	FUNCTION
1	Pass Light	Indicates no Arc and Leakage Current through insulation lower than Sensitivity Control's setpoint.
2	Fail Light	Indicates Arc and/or Leakage Current through insulation higher than Sensitivity Control's setpoint.
3	Sensitivity Control	Sets Pass/Fail point for the Breakdown Detection circuit. See "Breakdown Detection Circuit" for details in control operation.

Table 4. Control, Indicators, Connectors – MegaPulse series Breakdown Detection

Initial Checkout Procedure

The following procedure will verify that the Tester is working correctly. We recommend that this procedure be conducted periodically to ensure proper operation of the Tester.

The following items are needed to conduct this procedure:

A measuring instrument to monitor the output waveform. Always ensure that the measuring instrument (usually an oscilloscope with a high-voltage probe) is rated for the voltage involved, and that the frequency response of the instrument and probe are capable of measuring the output waveform of the MegaPulse Impulse Tester. A measuring instrument or probe with a low frequency response will result in erroneous readings that could be mis-read.

CAUTION

High voltage generated by the MegaPulse tester is exposed during this test. A risk of shock exists. Exercise care when using the MegaPulse tester.

1. Connect the Tester to a proper source of supply using the included 18 AWG power supply cord. Make sure that the front panel **VOLTAGE** adjust knob is turned fully counterclockwise.
2. Plug the Output and Return test leads in to the jacks on the front panel.
3. Connect the ends of the test leads to an appropriate measuring instrument (typically an oscilloscope with a high-voltage probe). Note that the **RETURN** lead is referenced to the chassis of the MegaPulse tester.
4. Turn the Tester on. Toggle the **POLARITY** switch if necessary so that the **NOR** indicator is lit.
5. Note that the Voltage meter may indicate that some residual voltage is present on the main storage capacitor, even when the tester is first turned ON. This is due to inherent charging of the internal capacitors. Pressing the **TRIGGER** switch will discharge the capacitors (be sure not to touch the output and return leads when pressing the trigger switch).
6. Push the yellow **CHARGE** button. Verify the red **TRIGGER** indicator is now lit.

7. Adjust the **VOLTAGE** knob so that the front panel LED display is reading a voltage that is suitable for the measuring instrument that is being used. Push the red **TRIGGER** button, and view the resulting impulse waveform on the measuring instrument.
8. Note that the peak amplitude of the measured output waveform is proportional to the voltage that is read of the front panel of the MegaPulse, but it will always be somewhat lower. This is because the meter on the MegaPulse is measuring the voltage on the main impulse storage capacitor (C1 in Figure 1). This voltage will intentionally dissipate to some extent before reaching the output leads. Therefore, it is important to measure the peak amplitude of the output waveform, and adjust the output of the MegaPulse accordingly.
9. Repeat steps 5 through 8, except this time toggle the **POLARITY** switch so that the **REV** indicator is lit. Note that the impulse waveform will now be a negative pulse, so it will probably be necessary to make adjustments to the measuring instrument to get a proper reading.
10. Adjust the **VOLTAGE** knob fully counterclockwise, to the minimum position. Turn the rear-panel power switch OFF.

NOTE: Steps 11-17 apply only to MegaPulse models with a defined current output waveform (with 2 waveform definitions in the Model Number). MegaPulse models with a single waveform definition in the Model Number are voltage waveform testers and the following steps need not be conducted.

11. Connect the Output and Return test leads across an appropriate current shunt, so that the Output lead is connected to one end of the current shunt, and the Return lead is connected to the other end of the current shunt. An example of a current shunt is shown here. If this current shunt example is used, calculate the current output using the measured resistance of the

shunt.

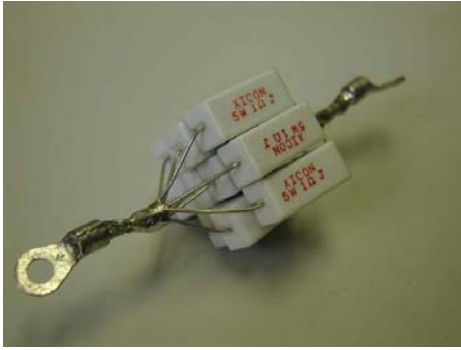

12. Connect the measuring instrument across the current shunt, keeping in mind that the Return lead is referenced to ground.
13. Turn the Tester on. Toggle the **POLARITY** switch if necessary so that the **NOR** or **REV** indicator is lit.
14. Push the yellow **CHARGE** button. Verify the red **TRIGGER** indicator is now lit.
15. Adjust the **VOLTAGE** knob so that the front panel LED display is reading a voltage that is suitable for the measuring instrument that is being used. Push the red **TRIGGER** button, and view the resulting impulse waveform on the measuring instrument.
16. Repeat steps 12 through 14, except this time toggle the **POLARITY** switch so that the **REV** indicator is lit. Note that the impulse waveform will now be a negative pulse, so it will probably be necessary to make adjustments to the measuring instrument to get a proper reading.
16. Adjust the **VOLTAGE** knob fully counterclockwise, to the minimum position. Turn the rear-panel power switch OFF.

Testing

This section describes how the MegaPulse Tester is used to conduct a test. The test can be stopped immediately at any time by turning OFF the rear-panel power switch.

1. Connect the Tester to a proper source of supply using the included 18 AWG power supply cord. Make sure that the front panel **VOLTAGE** adjust knob is turned fully counterclockwise.
2. Plug the Output and Return test leads in to the jacks on the front panel.
3. Connect the ends of the test leads to the equipment under test.

4. Connect the ends of the test leads to the optional 1000:1 voltage sense jack on the front panel (if provided). Alternatively, connect an appropriate measuring instrument (typically an oscilloscope with a high-voltage probe) to the equipment under test in order to monitor the results of the impulse test. Note that the **RETURN** lead is referenced to the chassis of the MegaPulse tester.
5. Turn the Tester on. Toggle the **POLARITY** switch as needed so that the **NOR** or **REV** indicator is lit.
6. Note that the Voltage meter may indicate that some residual voltage is present on the main storage capacitor, even when the tester is first turned ON. This is due to inherent charging of the internal capacitors. Pressing the **TRIGGER** switch will discharge the capacitors (be sure not to touch the output and return leads when pressing the trigger switch).
7. Push the yellow **CHARGE** button. Verify the red **TRIGGER** indicator is now lit.
8. Adjust the **VOLTAGE** knob so that the front panel LED display is reading a voltage that is suitable for the measuring instrument that is being used. Push the red **TRIGGER** button, and view the resulting impulse waveform on the measuring instrument.
9. Note that the peak amplitude of the measured output waveform is proportional to the voltage that is read of the front panel of the MegaPulse, but it will always be somewhat lower. This is because the meter on the MegaPulse is measuring the voltage on the main impulse storage capacitor (C1 in Figure 1). This voltage will intentionally dissipate to some extent before reaching the output leads. Therefore, it is important to measure the peak amplitude of the output waveform, and adjust the output of the MegaPulse accordingly.

TestMinder Operation

TestMinder computer operation is described in a specific manual included with your tester, if so equipped.

Please be sure to start TestMinder before the MegaPulse. For safety considerations, the MegaPulse output should be set to zero when energized.

EN60335 Pulse Trains

The MegaPulse Tester is a manual device. When the MegaPulse 1.2x50-7 is equipped with the 60335 Option, Including Fast Charge Supply and Virtual 12 ohm Impedance Output, Pulse trains of alternating polarity can be approximated by using the CHARGE, POLARITY and TRIGGER buttons on the front panel of the tester.

1. To begin the pulse train, push the CHARGE button. The MegaPulse will charge to the preset level within 2 sec.
2. Push the TRIGGER button, releasing the surge to the EUT. Immediately push the POLARITY button, which will switch the pulse polarity, in accordance with EN60335.
3. Push the CHARGE button.
4. Push the TRIGGER button. Time the sequence so the TRIGGER button is pushed every 2 seconds.

NOTE: If the MegaPulse is equipped with TestMinder, the pulse train information can be entered and the pulse trains will be under computer control. See the TestMinder Manual for details.

Breakdown Detection Circuit Option

The MegaPulse tester can optionally be configured with a Breakdown Detection circuitry that can detect a quickly decaying waveform, indicative of a breakdown in the insulation system being tested. This circuit detects abnormal current flows and interprets this flow as a failure of the insulation system being tested.

Proper operation requires calibration of the Sensitivity Control when the output voltage is

changed. For best results, a known good and a known bad sample of the insulation system can be used to set the Sensitivity Control. If these samples are not available, a starting setpoint can be set with the supplied calibration resistor (50 ohms).

Sensitivity setting using known good and known bad samples

1. Remove power to the MegaPulse and turn the Voltage Control to zero. Turn the Sensitivity Control to the maximum setting, i.e. the knob pointer at 5 o'clock.
2. Using the supplied High Voltage Test leads, connect the known bad sample across the High Voltage outputs of the MegaPulse.
3. Energize the MegaPulse and press the Charge Button. Use the Voltage Control to set the output to the desired level as shown on the MegaPulse voltage meter.
4. Press the TRIGGER button. The green PASS light should illuminate.
5. Retest, turning the Sensitivity Control to a progressively lower setting, until the red FAIL light lights. In general, the pointer on the knob will be at approximately 2 o'clock for 10-12kV and approximately 8 o'clock for 1-2kV test voltages.
6. Check the setting by substituting the known good sample in the circuit, and ensuring the result is a green PASS light. If it is not, the difference in resistance between the known good and known bad samples appears the same to the Breakdown Detection Circuit. It may help to repeat the setup using the known bad sample, and working to define the point of failure exactly by repeating tests until the exact point where the red FAIL light illuminates.
7. If the output voltage of the MegaPulse is changed, the Sensitivity Control should be reset.

Approximate Sensitivity Setting using the supplied 50 ohm resistor

If known good and known bad samples are not available, an approximate setting, using a 50 ohm resistor, is a recommended starting point. Depending on requirements of the particular test being conducted, a higher or lower resistance may be indicated. We have chosen the 50 ohm resistor as a balance between repeatability and sensitivity. As the resistance of the test resistor increases, current flow decreases, and this may

result in repeatability problems during the test setup. We recommend using the 50 ohm resistor at first, until the operator is familiar with the MegaPulse operation; at which time he may wish to experiment with other resistances as setpoints.

1. Remove power to the MegaPulse and turn the Voltage Control to zero. Turn the Sensitivity Control to the maximum setting, i.e. the knob pointer at 5 o'clock.
2. Using the supplied High Voltage Test leads, connect the test resistor across the High Voltage outputs of the MegaPulse.
3. Energize the MegaPulse and press the Charge Button. Use the Voltage Control to set the output to the desired level as shown on the MegaPulse voltage meter.
4. Press the TRIGGER button. The green PASS light should illuminate.
5. Retest, turning the Sensitivity Control to a progressively lower setting, until the red FAIL light lights. In general, the pointer on the knob will be at approximately 2 o'clock for 10-12kV and approximately 8 o'clock for 1-2kV test voltages.
6. If the output voltage of the MegaPulse is changed, the Sensitivity Control should be reset.

Defib-5 Checkout and Operation

The Defib-5 Medical Defibrillation tester consists of two parts; the pulse generation portion and the measurement portion. Please refer to the boxes shown in Fig. D-1, which is IEC 601-1, Figure 50 edited to show the function of the Defib-5. The lower box shows the part of the Defib-5 which generates the pulse, while the upper box shows the measurement network. The rest of Fig. D-1 is the EUT.

Use of Measurement Terminals Y1 and Y2

There are two BNC jacks on the front panel of the Defib-5, labeled Y1 and Y2. These are used to verify that the Applied Part or Chassis of the Equipment Under Test does not exceed 1 Volt peak in accordance with IEC/EN/UL 60601-1. A marginally failing product will cause the voltage on the oscilloscope to rise to 1 Volt (ref. 60101-1 clause 17h) . Note that this voltage does not have the same waveshape as the defibrillation pulse. The measurement point has a voltage rise time constant of 2 mSec (derived empirically). The decay time of the measurement point is

driven by the impedance of the oscilloscope, which is typically 1 MegOhm. In this case, the decay time would have a time constant of 1 second.

Verification of Measurement Circuit Operation

To verify proper oscilloscope setup and to ensure that you can capture a waveform, set up the time base of the oscilloscope to 100mS/division. Connect the Defib-5's Y1 and Y2 jacks to the Ch1 and Ch2 inputs respectively of an oscilloscope using appropriate BNC cables. Set up the oscilloscope to perform a (Ch1 - Ch2) math function. (Depending on the particular oscilloscope used, it will be necessary to experiment with the trigger setting in order to ensure that you will be able to capture the signal.)

Connect the Measuring Point input jack on the front panel of the Defib-5 directly to the Output jack on the front panel of the Defib-5 using the lead supplied with the tester. Set the output of the Defib-5 to minimum using the Voltage Knob. Press the CHARGE button, and adjust the Voltage output so that the front panel meter reads 100 volts (note that this is much lower than the standard test voltage of 5000 volts). Press the TRIGGER button and verify that the voltage captured by the oscilloscope rises to approx. 2.5 volts. Refer to Figure D-2 which shows what the signal should look like. This will show that the voltage divider network of the Defib-5 which is connected to the Y1 and Y2 jacks is functioning as intended.

Testing with the Defib-5

To perform actual testing, the Defib-5 is connected to the EUT as shown in the attached drawing. Note the actual connections on the front panel of the Defib-5 have been added to Figure 50 of IEC 601 for illustrative purposes as shown in Figure D-1 of this manual.

Page 199 bis

Add the following new figures 50 and 51:

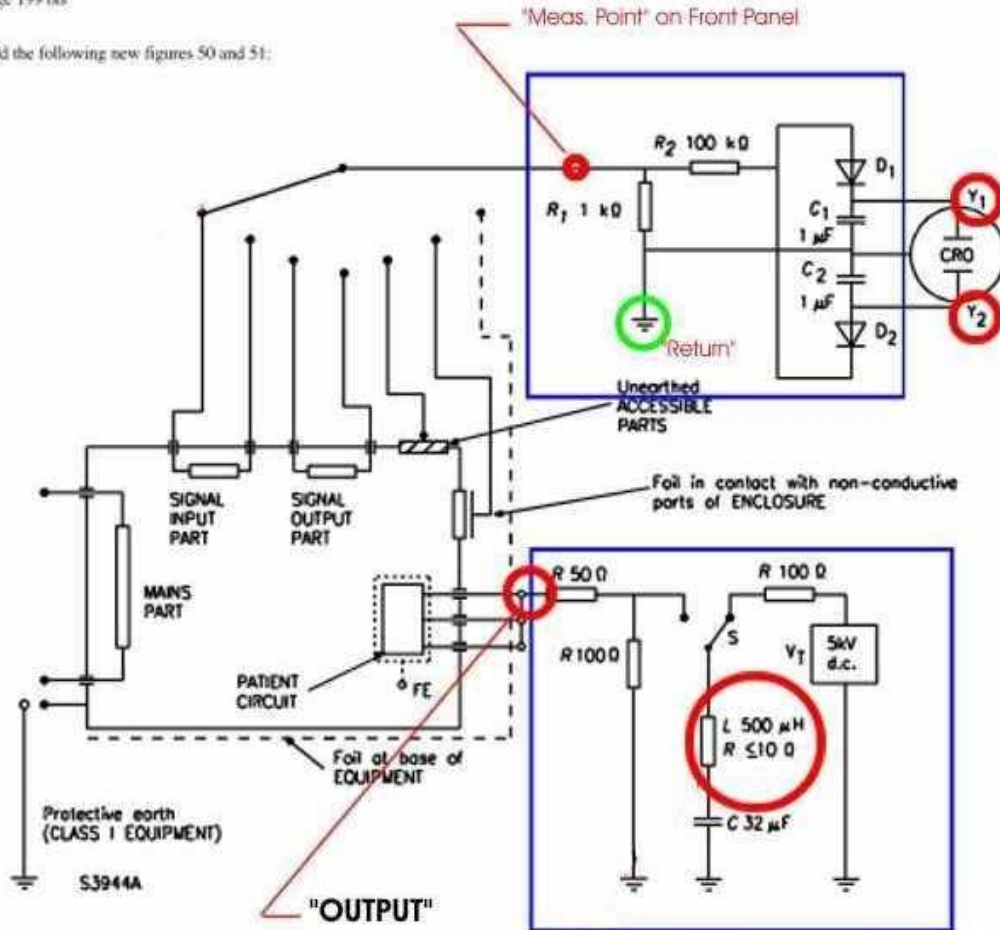
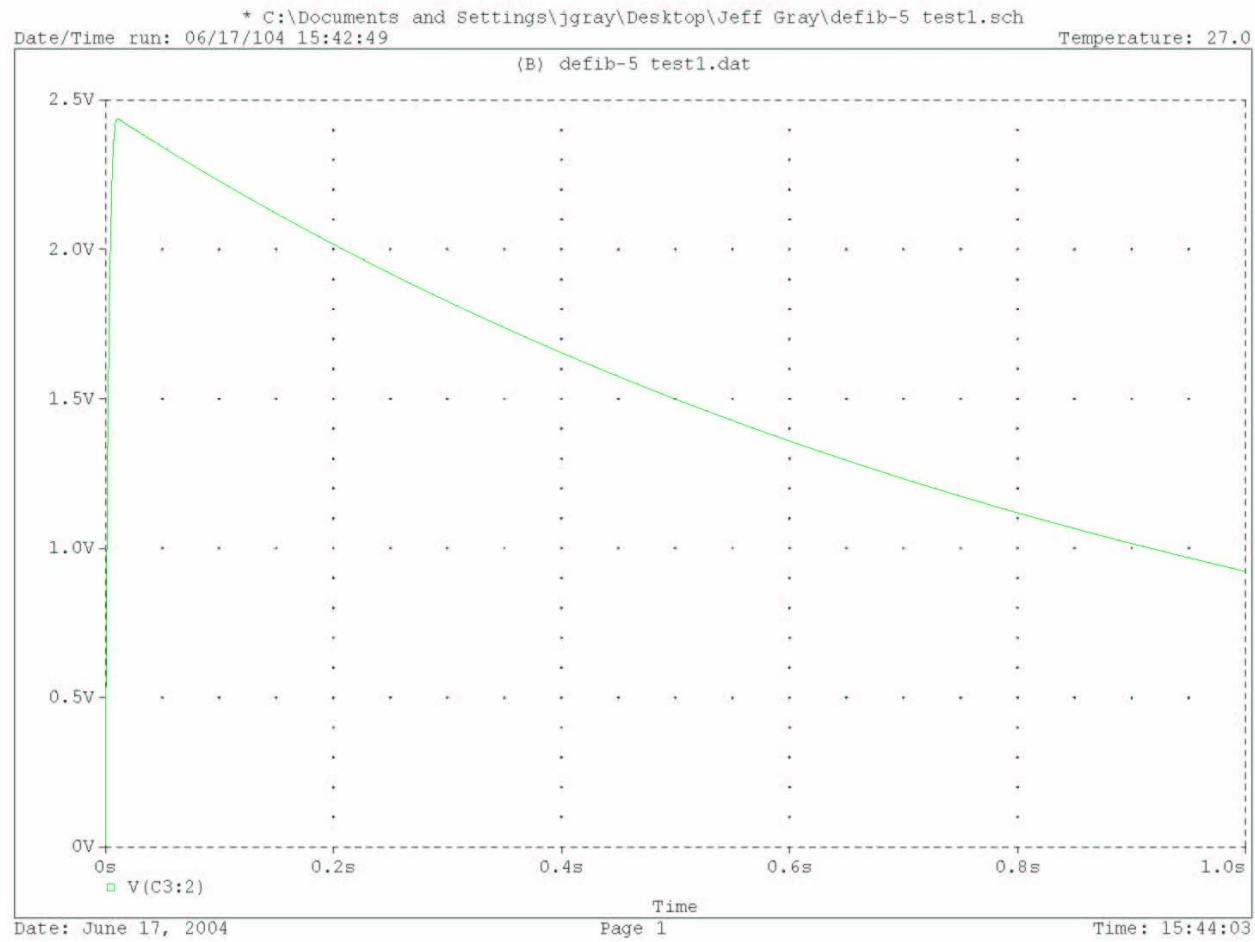

Figure 50 – Application of test voltage to bridged PATIENT CONNECTIONS for DEFIBRILLATION-PROOF APPLIED PARTS (see subclause 17.4(b))

Figure D-1: Defib-5 Connections 1

Figure D-2: Y1 Y2 Test Output 1



Section 4

Technical Assistance

For Technical Assistance

Phone: (800) 748-6224

Technical Assistance is available from Compliance West USA between the hours of 8:30 AM and 5:00 PM Pacific Time.

Compliance West USA

7915 Silverton Ave. #315

San Diego, CA 92126

Phone: (858) 860-0277

FAX: (858) 860-0279

Technical information is also available on our web site at:
www.compwest.com

Section 5

Maintenance and Calibration

WARNING

THESE SERVICE INSTRUCTIONS ARE FOR USE BY QUALIFIED PERSONNEL ONLY. TO AVOID ELECTRIC SHOCK, DO NOT PERFORM ANY SERVICING OTHER THAN THAT CONTAINED IN THE OPERATING INSTRUCTIONS UNLESS YOU ARE QUALIFIED TO DO SO.

Introduction

This section of the manual contains maintenance information for the MegaPulse series impulse tester. This maintenance information is divided into service information, general maintenance, a performance test, and a calibration procedure. The performance test is recommended as an acceptance test when the instrument is first received, and later as a preventative maintenance tool to verify proper instrument operation. A 1-year calibration cycle is recommended to maintain the specifications given in Section 1. The test equipment required for the performance test is an oscilloscope and high voltage probe, and a calibrated current shunt. The test equipment required for the calibration procedure is a DMM able to read the maximum specified peak output voltage of the MegaPulse tester.

Service Information

The MegaPulse tester is warranted to the original purchaser for a period of 1 year. This warranty does not cover problems due to misuse or neglect.

Malfunctions which occur within the limits of the warranty will be corrected at no charge. Mail the instrument post paid to the manufacturer. Dated proof of purchase is required for all in-warranty repairs.

The manufacturer is also available for calibration and / or repair of instruments that are beyond their warranty period. Contact the manufacturer for a cost quotation. Ship the instrument and your remittance according to the instructions given by the manufacturer.

General Maintenance

Interior Access

NOTE

To avoid contaminating the PWB with oil from your fingers, handle it by the edges or wear gloves. If the PWB becomes contaminated, refer to the cleaning procedures given later in this section.

Calibration Access

Use the following procedures to gain access to the calibration adjustments of your instrument.

1. Set Line Power switch to OFF.
2. Disconnect the power cord from the rear of the instrument.
3. Remove the two upper screws on each side of the unit.

4. Grasp the top of the enclosure clamshell and lift it off the front and rear panels.
5. All calibration adjustments are now accessible.

NOTE

With the power cord replaced, the instrument is operational for service.

WARNING

Dangerous voltages exist when energized. Exercise extreme care when working on an energized circuit.

6. To reassemble, reverse steps 1-5 above.

Cleaning

CAUTION

Do not use aromatic hydrocarbons or chlorinated solvents for cleaning. These solutions will react with the plastic materials used in the instrument.

Clean the front panel and case with a mild solution of detergent and a damp sponge. Clean dust from the PWB with clean, dry, low pressure (<20 psi).

Performance Test

The performance test evaluates the performance of your instrument to ensure that the logic, lights and high voltage sections are working properly. This test is recommended for incoming inspection, as a preventative maintenance check, and to verify proper operation during the calibration procedure. It is not necessary to disassemble the instrument to conduct these tests. If the instrument fails any part of the performance test, repair is indicated.

Allow the instrument to stabilize and perform the test at an ambient temperature of 23°C ±5°C (73°F ±9°F).

1. Connect the Tester to a proper source of supply using the included 18 AWG power supply cord. Make sure that the front panel **VOLTAGE** adjust knob is turned fully counterclockwise.

2. Plug the Output and Return test leads in to the jacks on the front panel.
3. Connect the ends of the test leads to the optional 1000:1 voltage sense jack on the front panel (if provided) or an appropriate measuring instrument (typically an oscilloscope with a high-voltage probe). Note that the **RETURN** lead is referenced to the chassis of the MegaPulse tester.
4. Turn the Tester on. Toggle the **POLARITY** switch if necessary so that the **NOR** indicator is lit.
5. Note that the Voltage meter may indicate that some residual voltage is present on the main storage capacitor, even when the tester is first turned ON. This is due to inherent charging of the internal capacitors. Pressing the **TRIGGER** switch will discharge the capacitors (be sure not to touch the output and return leads when pressing the trigger switch).
6. Push the yellow **CHARGE** button. Verify the red **TRIGGER** indicator is now lit.
7. Adjust the **VOLTAGE** knob so that the front panel LED display is reading a voltage that is suitable for the measuring instrument that is being used - preferably close to the maximum output voltage of the MegaPulse tester. Push the red **TRIGGER** button, and view the resulting impulse waveform on the measuring instrument.
8. A copy of the actual voltage waveforms (rise and duration) that were measured on your instrument before shipping are included at the end of this manual (figures 4 and 6). These waveforms are identified by the serial number of your MegaPulse tester in the upper left-hand corner of the figure(s). Compare the impulse waveform to these "as shipped" waveforms, as well as the ideal waveforms (theoretical calculated values) that are also included at the end of this manual (figures 5 and 7). If the measured waveform is significantly different than the ideal waveform, then additional evaluation and/or repair of the MegaPulse tester is warranted.
9. Note that the peak amplitude of the measured output waveform is proportional to the voltage that is read of the front panel of the MegaPulse, but it will always be somewhat lower. This is because the meter on the MegaPulse is measuring the voltage on the main impulse storage

capacitor (C1 in Figure 1). This voltage will intentionally dissipate to some extent before reaching the output leads. Therefore, it is important to measure the peak amplitude of the output waveform, and adjust the output of the MegaPulse accordingly.

10. Repeat steps 5 through 9, except this time toggle the **POLARITY** switch so that the **REV** indicator is lit. Note that the impulse waveform will now be a negative pulse, so it will probably be necessary to make adjustments to the measuring instrument to get a proper reading.
11. Adjust the **VOLTAGE** knob fully counterclockwise, to the minimum position. Turn the rear-panel power switch OFF.
12. Connect the Output and Return test leads across an appropriate current shunt, so that the Output lead is connected to one end of the current shunt, and the Return lead is connected to the other end of the current shunt.
13. Connect the measuring instrument across the current shunt, keeping in mind that the Return lead is referenced to ground.
14. Turn the Tester on. Toggle the **POLARITY** switch if necessary so that the **NOR** indicator is lit.
15. Push the yellow **CHARGE** button. Verify the red **TRIGGER** indicator is now lit.
16. Adjust the **VOLTAGE** knob so that the front panel LED display is reading a voltage that is suitable for the measuring instrument that is being used. Push the red **TRIGGER** button, and view the resulting impulse waveform on the measuring instrument.
17. Compare the impulse waveform to the appropriate ideal waveform that is included at the end of this manual (figures 8 and 9). Note that the measured waveform may differ from the "ideal" waveform because of lead inductance, inductance of the current shunt, etc. It is often difficult to make a comparison between the "real world" and the "ideal case" because these inductances will have a significant effect on the high-current output waveform. If the measured waveform is significantly different than the ideal waveform, then additional evaluation and/or repair of the MegaPulse tester is warranted.

18. Repeat steps 14 through 17, except this time toggle the **POLARITY** switch so that the **REV** indicator is lit. Note that the impulse waveform will now be a negative pulse, so it will probably be necessary to make adjustments to the measuring instrument to get a proper reading.
19. Adjust the **VOLTAGE** knob fully counterclockwise, to the minimum position. Turn the rear-panel power switch OFF.

If the results of the performance test are not in accordance with the above, service is required. Remove the Tester from service and contact the manufacturer for servicing information. If the results of the tests above are correct, proceed with the Calibration Procedure.

Calibration Procedure

The Calibration Procedure should be performed annually and any time the instrument has been repaired. The calibration procedure consists of calibrating the meter reading to agree with the voltage output.

The Performance test in the previous section should be performed with satisfactory results before conducting the Calibration procedure.

Before starting the Calibration procedure, perform the Calibration access procedure given earlier in this Section.

NOTE

Allow the instrument to stabilize for approximately five minutes. Perform all calibration adjustments at an ambient temperature of 23°C ±5°C (73°F ±9°F).

WARNING:

Calibration Adjustments Are Performed On Live Circuits. Exercise Caution At All Times, And Use A Non-Conductive Tool For All Adjustments.

Voltage Calibration Adjustment

Use the following procedure to calibrate the output voltage. Pot R6 and R7 are located on the back side of the front panel LED display board. Verify the location of these two potentiometers after the top cover of the tester has been removed, but before the power cord has been

plugged into the tester. Also verify the location of the positive (red) and negative (black) Voltage Output Test Points, which are used to measure the output voltage.

1. Plug in the power cord. Adjust the front panel **VOLTAGE** knob fully counterclockwise to the minimum position. Turn the rear-panel power switch ON. The **CHARGE** indicator should be lit.
2. Toggle the **POLARITY** switch from **NOR** to **REV**. Adjust R6 so that the voltage reading on the front panel LED display is as close to zero in both **NOR** and **REV** positions. Note that the display may read some residual voltage of approximately 10 volts.
3. Connect a suitable DC voltage meter to the Voltage Output Test Points. The red test point is positive; the black test point is negative.
4. Press the **CHARGE** button. Use the **VOLTAGE** adjustment knob to increase the output voltage to near the maximum rated peak output voltage of the MegaPulse tester.
5. Using a non-conductive screwdriver, adjust R7 so that the voltage reading on the front panel LED display agrees with the voltage reading on the DC voltage meter.
6. Turn the **VOLTAGE** adjust knob back down to zero. Allow the output voltage to decay down to a safe level (this may take a few minutes). Remove the DC voltage meter leads.
7. Turn the rear-panel power switch OFF, and replace the top cover of the MegaPulse tester.

If the results of the calibration procedure are not in accordance with the above, service is required. Remove the Tester from service and contact the manufacturer for servicing information. If the results of the tests above are correct, the tester may be put back into use.

Figures 4-9

Figures 4 to 9 follow this page. The individual figures may not be identified with the Figure number, but are in order as follows:

Figure 4: Actual measured waveform of the Voltage rise time. Voltage rise time is defined as follows (per ANSI/IEEE C62.41 and other standards): $\text{trise} = 1.67(t_{90} - t_{30})$, where t_{90} and t_{30} = the times of the 90% and 30% amplitude points on the leading edge of the waveform.

Figure 5: Calculated (theoretical) Voltage rise time based on a computer simulation using the ideal component values. Voltage rise time is defined as follows (per ANSI/IEEE C62.41 and other standards): $\text{trise} = 1.67(t_{90} - t_{30})$, where t_{90} and t_{30} = the times of the 90% and 30% amplitude points on the leading edge of the waveform.

Figure 6: Actual measured waveform of the Voltage duration. The duration is defined (per ANSI/IEEE C62.41 and other standards) as the time between virtual origin and the time of the 50% pint on the tail. The virtual origin is the point where a straight line between the 30% and 90% points on the leading edge of the waveform intersects the $V = 0$ line.

Figure 7: Calculated (theoretical) Voltage duration based on a computer simulation using the ideal component values. The duration is defined (per ANSI/IEEE C62.41 and other standards) as the time between virtual origin and the time of the 50% pint on the tail. The virtual origin is the point where a straight line between the 30% and 90% points on the leading edge of the waveform intersects the $V = 0$ line.

Figure 8: Calculated (theoretical) Current rise time based on a computer simulation using the ideal component values. Current rise time is defined as follows (per ANSI/IEEE C62.41 and other standards): $\text{trise} = 1.25(t_{90} - t_{10})$, where t_{90} and t_{10} = the times of the 90% and 10% amplitude points on the leading edge of the waveform.

Figure 9: Calculated (theoretical) Current duration based on a computer simulation using the ideal component values. The duration is defined (per ANSI/IEEE C62.41 and other standards) as the time between virtual origin and the time of the 50% pint on the tail. The virtual

origin is the point where a straight line between the 10% and 90% points on the leading edge of the waveform intersects the $I = 0$ line.

