

LCB
Leakage Current
Measurement
Instrument

Instruction Manual

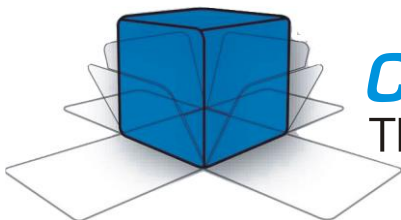

COMPLIANCE WEST USA

The blue box that tests. And tests.

Dear Customer:

Congratulations! Compliance West USA is proud to present you with your LCB leakage current measurement instrument. Your instrument features state-of-the-art accuracy for making leakage current measurements.

To fully appreciate all the features of your new instrument, we suggest that you take a few moments to review this manual. Compliance West USA stands by your instrument with a full one-year warranty. If the need arises, please don't hesitate to call on us.

Thank you for your trust and confidence.

Table of Contents

Section 1	6
An Introduction to leakage current testing with the LCB	6
Safety Precautions.....	6
Test Personnel.....	6
Testing Area.....	6
Section 2	7
Introduction	7
Specifications	7
Configuration 1	8
Configuration 2	8
Configuration 3	8
Configuration 4	9
Configuration 5	9
Configuration 6.....	10
Configuration UL.....	10
Section 3	11
Operation.....	11
Setting up your Tester.....	11
Fuse Verification Check	11
Verification of Proper Operation	12
Section 4	13
Technical Assistance	13
Section 5	14
Maintenance and Calibration	14
Introduction.....	14
Service Information	14
General Maintenance	14
Cleaning	14
Calibration Information	14
Appendix A	15
Tolerance comparison for LCB Configuration 1	15
Tolerance comparison for LCB Configuration 2	16
Tolerance comparison for LCB Configuration 3	17
Tolerance comparison for LCB Configuration 4.....	18
Tolerance comparison for LCB Configuration 5.....	19
Tolerance comparison for LCB Configuration 6.....	20
Tolerance comparison for LCB Configuration UL	21

Section 1

An Introduction to leakage current testing with the LCB

Some amount of leakage current exists in all modern electrical and electronic equipment that connects to an AC power source. Leakage current is always unintentional: either due to capacitive coupling from the AC mains circuit to ground (such as exists in AC motors) or as an unintended side effect of EMI suppression components (such as capacitors connected from AC mains to the chassis of the equipment). The amount of leakage current and the particular measurement methods are governed by various end-product safety standards. These standards often refer to the international standard IEC 60990 - Methods of Measurement of Touch Current and Protective Conductor Current for the design and specification of the leakage current measurement network.

Compliance West USA offers several different leakage current networks in order to perform testing to numerous end-product standards. All these networks comply with the requirements of the International Committee of Testing Laboratories Operational Procedure 113 (IECEE CTL-OP 113 Ed. 1.1). This document outlines requirements for design, calibration, and frequency response of the leakage measurement instrument.

The Compliance West USA LCB leakage current measurement instruments are leakage current networks only - they must be used with a suitable voltmeter in order to perform leakage current measurements. The voltmeter used can significantly affect the results of the measurement. The voltmeter used must have adequate frequency response to measure the AC leakage-current voltages and have an input impedance of 1 MegOhm or greater.

Safety Precautions

Leakage current testing is inherently dangerous because the Equipment Under Test (EUT) is generally ungrounded during testing. In some safety standards, an additional single-fault condition is introduced during leakage current testing, which may expose the test operator to hazardous or even lethal voltages.

Test Personnel

Test operators must be properly trained in the procedures for safety performing leakage current testing. Metal jewelry should not be worn during testing. Operators should not allow others into the testing area, especially when tests are being conducted. Organization is to be stressed. The operator should keep the test area free of unused leads and equipment.

Testing Area

The area used for conducting leakage current tests should be as remote as possible from normal production line activities. Only personnel conducting the test should be allowed in the area, and it should be taped or roped off to preclude casual entry by other employees. In addition, the area should be marked "WARNING - HIGH VOLTAGE TESTING" or the equivalent to warn others of the nature of the testing taking place.

The bench being used should be non-conductive, and any exposed metal parts should be tied together and grounded.

Section 2

Introduction

This manual contains a description of all the available LCB models. Each LCB instrument contains only one leakage current network configuration.

Your instrument is warranted for a period of one year upon shipment of the instrument to the original purchaser.

Specifications

All LCB models include an input fuse to protect against excessive current that could damage the leakage current network. If the LCB is used incorrectly, the internal fusing may not protect the internal network components from damage. Such damage is not covered under warranty. For continued protection against risk of fire or electric shock, replace the internal fuse only with a type and rating as specified in this manual.

Voltage Rating	0-264Vrms AC to enclosure, O.V. Cat II, 50-440Hz at input terminals ¹
Current Rating	100mA maximum
Fuse Rating (F1)	Littelfuse 370 series, type TR5, rated 63mA, 250V, fast-acting ²
Environmental	10-90°rH, non-condensing; 0-2000m altitude; 10-40°C
Components	High-frequency, low-parasitic, individually selected to maintain +/- 1.0% tolerance
Frequency Response ³	50-60 Hz: +/- 3.5% accuracy >60 Hz - 1MHz: +/- 5% accuracy

Note 1: Current exceeding the current rating will cause the fuse to open

Note 2: Fuse is specified to hold for 1 hour (not open) at 150% of the fuse current rating

Note 3: LCB observed accuracy is in accordance with CTL Decision Sheet no. DSH 251b and e. See Appendix A for tolerance graphs.

AVAILABLE MODELS

MODEL	IEC 60990:1999	IEC 61010-1:2010	IEC60950-1:2005	IEC 60335-1:2012	IEC 60601-1:2012
CONFIG 1	Fig. 3 (unweighted)	Fig. A.3 (electrical burns)			
CONFIG 2	Fig. 4 (perception)	Fig. A.1 (dc and ≤ 1MHz)	Fig. D.1	Cl. 13.2 and Fig. 1-4	
CONFIG 3	Fig. 5 (let-go)				
CONFIG 4					Fig. 12
CONFIG 5		Fig. A.2 (dc and ≤ 100Hz)			
CONFIG 6		Fig. A.4 (wet contact)			

MODEL	UL 763
CONFIG UL	Cl.35.5

Configuration 1

Configuration 2

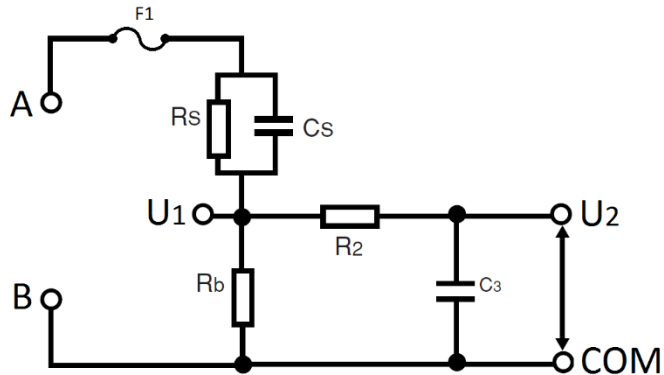

Table 2 Configuration 2 Specifications

A, B	Input terminals to connect to EUT
R_s	1500 Ohm
C_s	0.22 μ F
R_b	500 Ohm
R_2	10 kOhm
C_3	0.022 μ F
U1, U2, COM	Output terminals for connection to voltmeter

Configuration 3

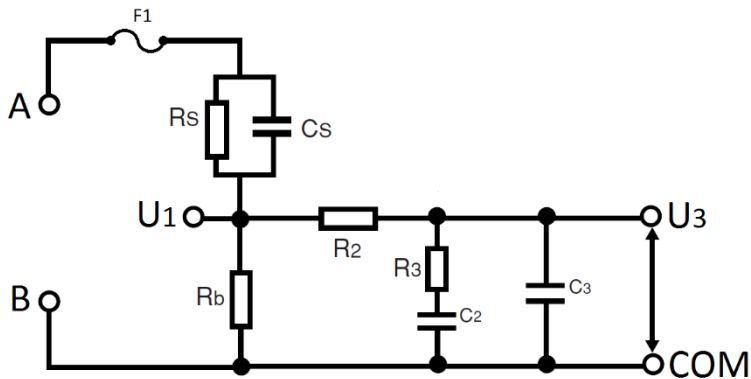

Table 3 Configuration 3 Specifications

A, B	Input terminals to connect to EUT
R_s	1500 Ohm
C_s	0.22 μ F
R_b	500 Ohm
R_2	10 kOhm
R_3	20 KOhm
C_2	0.0062 μ F
C_3	0.0091 μ F
U1, U3, COM	Output terminals for connection to voltmeter

Configuration 4

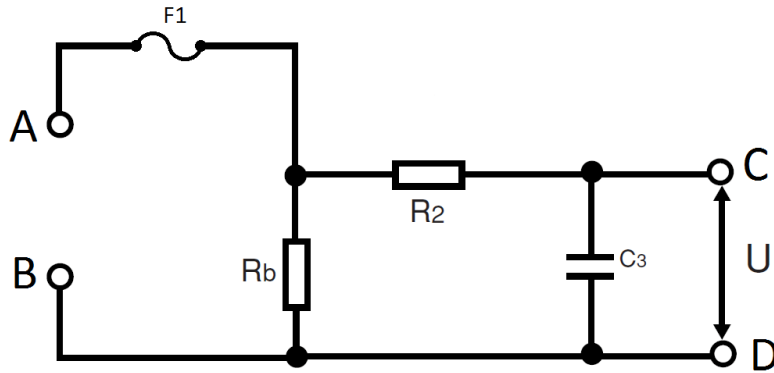

Table 4 Configuration 4 Specifications

A, B	Input terminals to connect to EUT
Rb	1000 Ohm
R2	10 kOhm
C3	0.015 uF
C, D	Output terminals for connection to voltmeter

Configuration 5

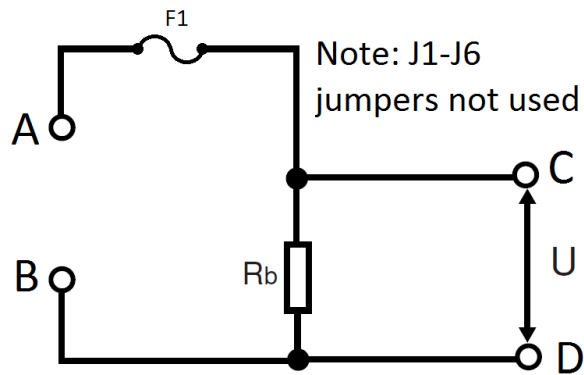

Table 5 Configuration 5 Specifications

A, B	Input terminals to connect to EUT
Rb	2000 Ohm
C, D	Output terminals for connection to voltmeter

Configuration 6

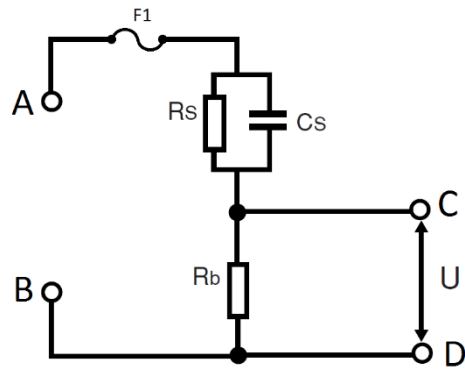

Table 6 Configuration 6 Specifications

A, B	Input terminals to connect to EUT
R_s	375 Ohm
C_s	0.22 μ F
R_b	500 Ohms
C, D	Output terminals for connection to voltmeter

Configuration UL

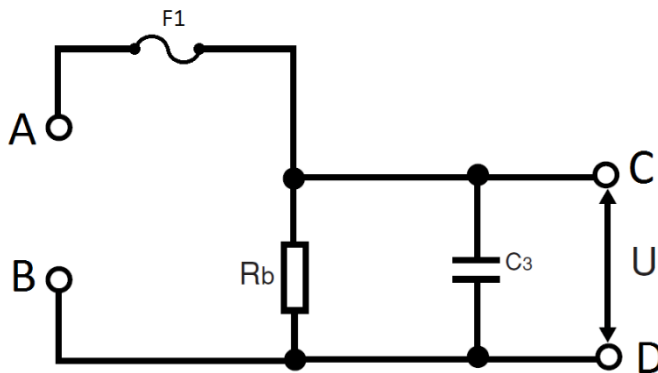

Table 7 Configuration UL Specifications

A, B	Input terminals to connect to EUT
R_b	1500 Ohm
C_3	0.15 μ F
C, D	Output terminals for connection to voltmeter

Section 3

Operation

This section describes how to set up and make measurements with your instrument. We recommend that you read the entire section carefully so that you can use all the features of your instrument.

Setting up your Tester

Your LCB leakage current measurement instrument is shipped with one cable that connects to a detachable terminal block on the input and output side on the front of the instrument see Figure 1 below for reference. The other end of the input cable is un-terminated, these wires should be connected to the EUT and the voltmeter to the output connector. Note that the cables may be disconnected from the terminal blocks if you choose to use other test leads, but tolerances might be affected.

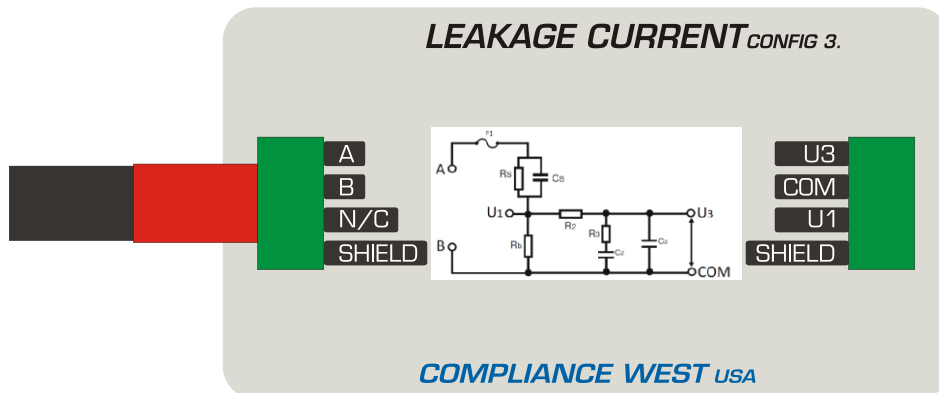

Figure 1 Test lead wiring.

The provided test cable is shielded, and the cable shield is connected to the metal enclosure of the LCB instrument. The shielded cable may be left unterminated or grounded as needed for testing.

Fuse Verification Check

To check the fuse, connect an ohmmeter between **A** and **B**. An open circuit measurement indicates an open fuse, and the fuse must be replaced before use.

Verification of Proper Operation

Once your LCB has successfully passed the fuse verification, you can proceed to perform verification of proper operation, for this matter use a DC ohmmeter. Please refer the following table to know the measurements points and the expected value depending on your LCB configuration. If any of your measurements are out of tolerance, please contact the manufacturer for further assistant.

Table 8 LCB Verification Points and Values

LCB	Measurements points	Expected Value (Ω)	Tolerance (Ω)
Config 1	A-B	2000	1980 - 2020
	A-C	1500	1485 - 1515
	C-D	500	495 - 505
Config 2	A-U1	1500	1485 - 1515
	U1-B	500	495 - 505
	A-B	2000	1980 - 2020
	U1-U2	10000	9900 - 10100
Config 3	A-U1	1500	1485 - 1515
	U1-B	500	495 - 505
	A-B	2000	1980 - 2020
	U1-U3	10000	9900 - 10100
Config 4	A-B	1000	990 - 1010
	A-C	10000	9900 - 10100
	B-C	11000	10890 - 11110
Config 5	A-B	2000	1980 - 2020
	C-D	2000	1980 - 2020
Config 6	A-C	375	371.25 - 378.75
	A-B	875	866.25 - 883.75
	B-C	500	495 - 505
Config UL	A-B	1500	1485 - 1515
	B-C	1500	1485 - 1515

Section 4

Technical Assistance

Technical Assistance from Compliance West USA is available:

Phone: (800) 748-6224

Hours: 8:00 AM - 4:00 PM Pacific Time.

Also available on our web site at: **www.compwest.com**

Contact:

Compliance West USA
650 Gateway Center Way, Suite D
San Diego, CA., 92102
United States of America.

Phone: (619) 878-9696

FAX: (619) 794-0404

Section 5

Maintenance and Calibration

WARNING

MAINTENANCE AND CALIBRATION INSTRUCTIONS ARE FOR QUALIFIED PERSONNEL ONLY. TO AVOID ELECTRIC SHOCK, DO NOT PERFORM ANY SERVICING OTHER THAN THE CONTAINED IN THE OPERATING INSTRUCTIONS.

Introduction

This section of the manual contains maintenance information for the LCB leakage measurement instrument. A 1-year calibration cycle is recommended to maintain the specifications of the factory.

Service Information

The LCB tester is warranted to the original purchaser for a period of 1 year. This warranty does not cover problems due to misuse or neglect. Malfunctions which occur within the limits of the warranty will be corrected at no charge. Mail the instrument post paid to the manufacturer. Dated proof of purchase is required for all in-warranty repairs. The manufacturer is also available for calibration and / or repair of instruments that are beyond their warranty period. Contact the manufacturer for a cost quotation. Ship the instrument and your remittance according to the instructions given by the manufacturer.

General Maintenance

To avoid contaminating the PWB with oil from your fingers, handle it by the edges or wear gloves. If the PWB becomes contaminated, refer to the cleaning procedures given later in this section.

WARNING

Remove all external connections before opening the LCB. Do not connect the LCB to hazardous live circuits with the internal circuitry exposed.

CAUTION

Do not use aromatic hydrocarbons or chlorinated solvents for cleaning. These solutions will react with the plastic materials used in the instrument.

CLEANING

Clean the exterior of the LCB with a mild solution of detergent and a damp sponge. Clean dust from the PWB with clean, dry, low pressure (<20 psi).

Calibration Information

The Calibration Procedure should be performed annually and any time the instrument has been repaired. The calibration procedure should be performed at an ambient temperature of $23^{\circ}\text{C} \pm 5^{\circ}\text{C}$ ($73.4^{\circ}\text{F} \pm 9^{\circ}\text{F}$). The Calibration procedure must be performed by qualified personnel, for more information contact Compliance West USA.

Appendix A

Tolerance comparison for LCB Configuration 1

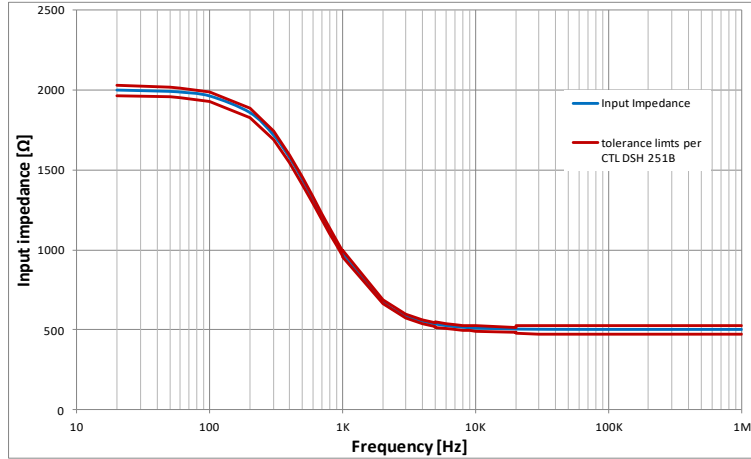

Figure A1. Input Impedance vs Frequency

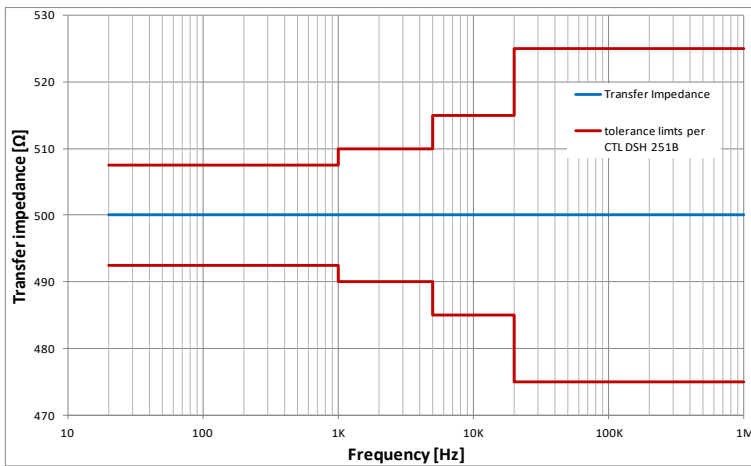

Figure A2. Transfer Impedance vs Frequency

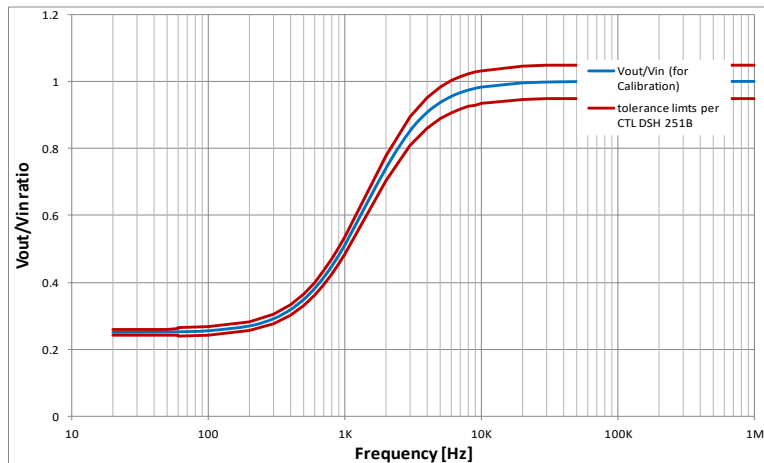

Figure A3. Vout/Vin Ratio vs Frequency

Tolerance comparison for LCB Configuration 2

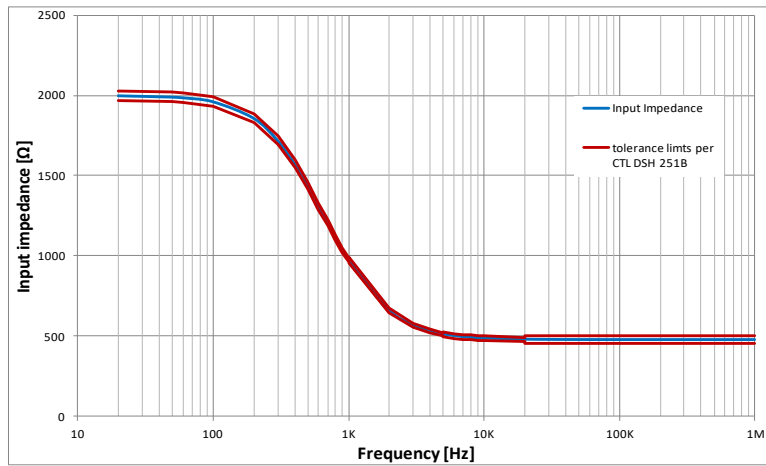

Figure A4. Input Impedance vs Frequency

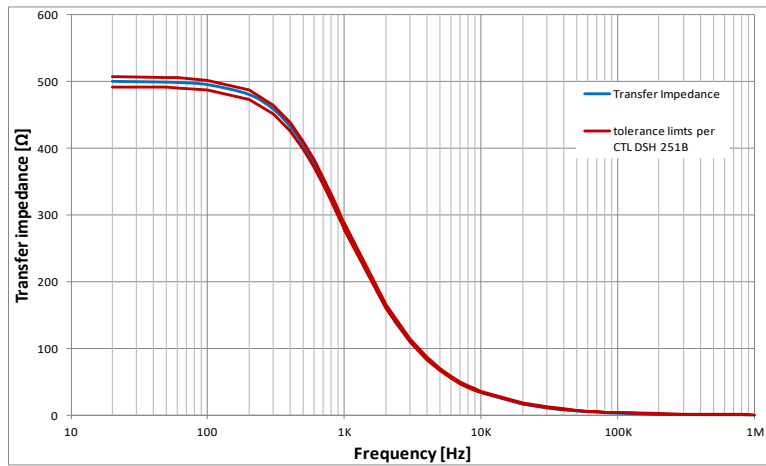

Figure A5. Transfer Impedance vs Frequency

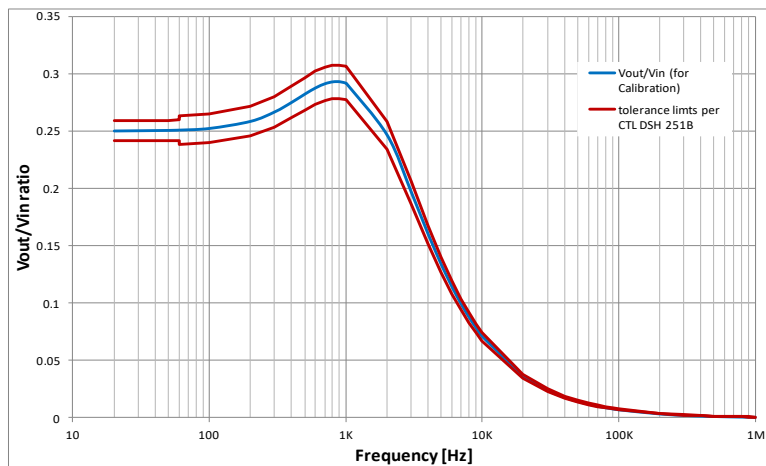

Figure A6. Vout/Vin Ratio vs Frequency

Tolerance comparison for LCB Configuration 3

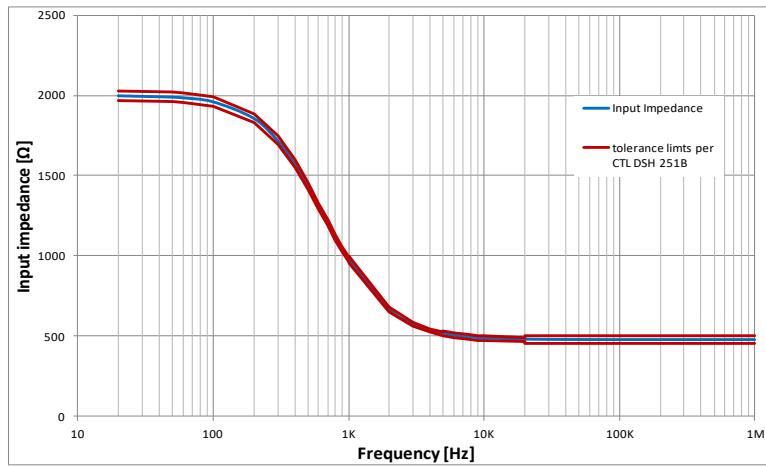

Figure A7. Input Impedance vs Frequency

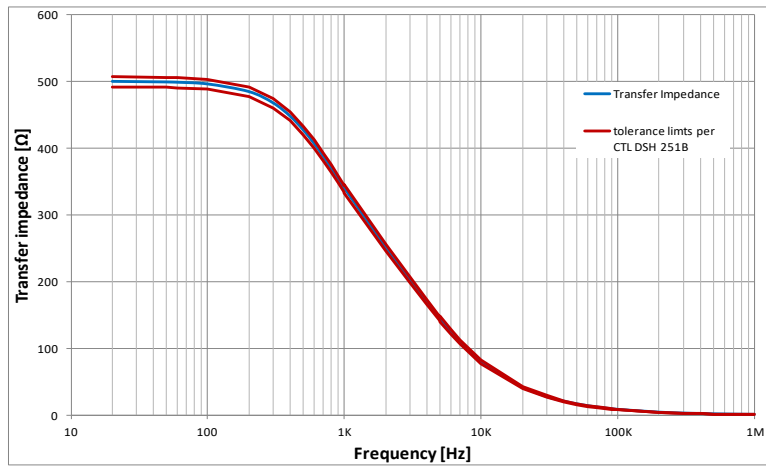

Figure A8. Transfer Impedance vs Frequency

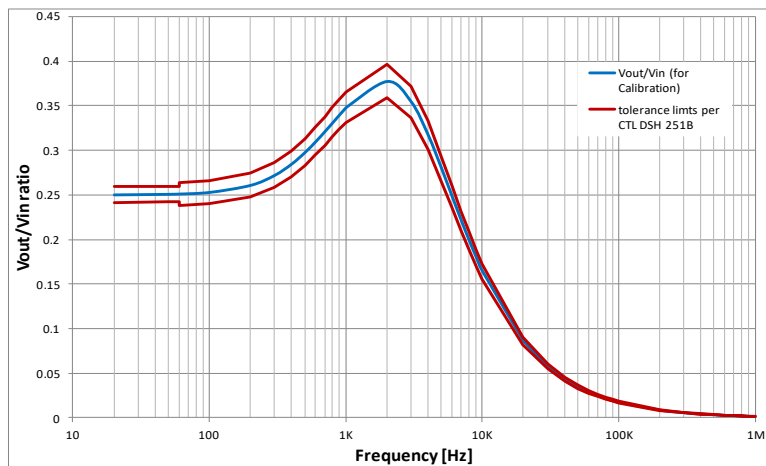

Figure A9. Vout/Vin Ratio vs Frequency

Tolerance comparison for LCB Configuration 4

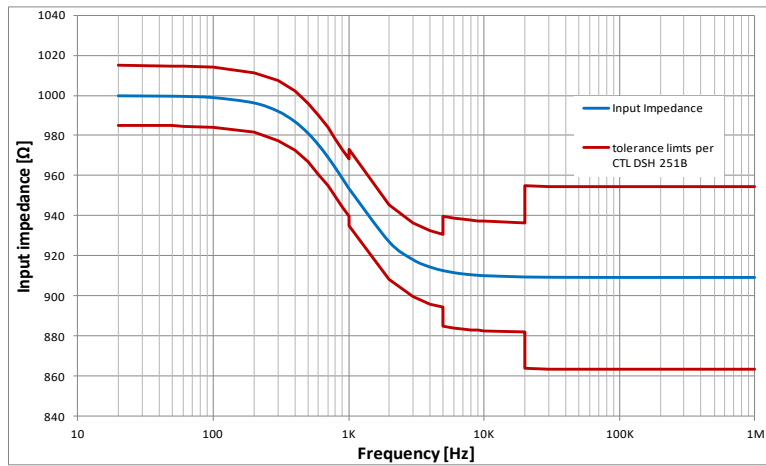

Figure A10. Input Impedance vs Frequency

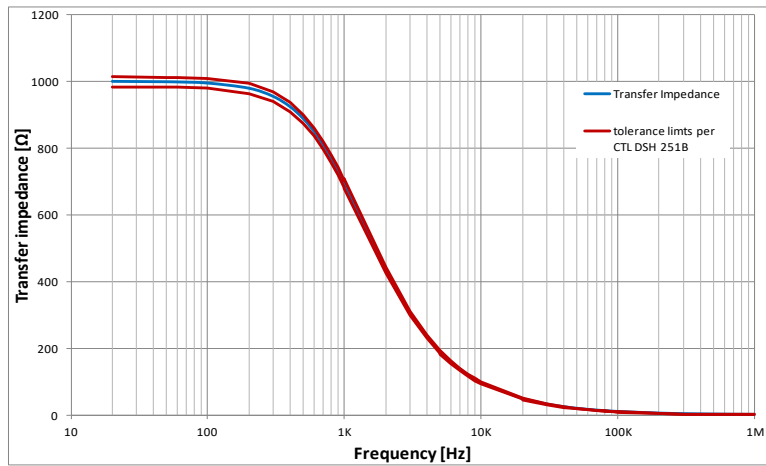

Figure A11. Transfer Impedance vs Frequency

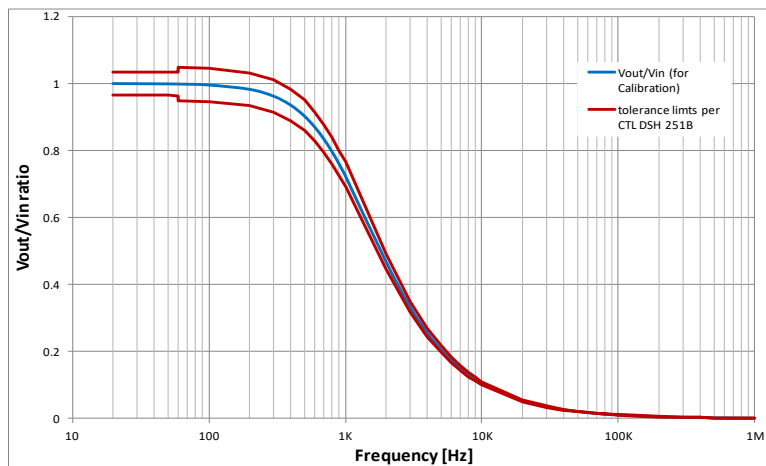

Figure A12. Vout/Vin Ratio vs Frequency

Tolerance comparison for LCB Configuration 5

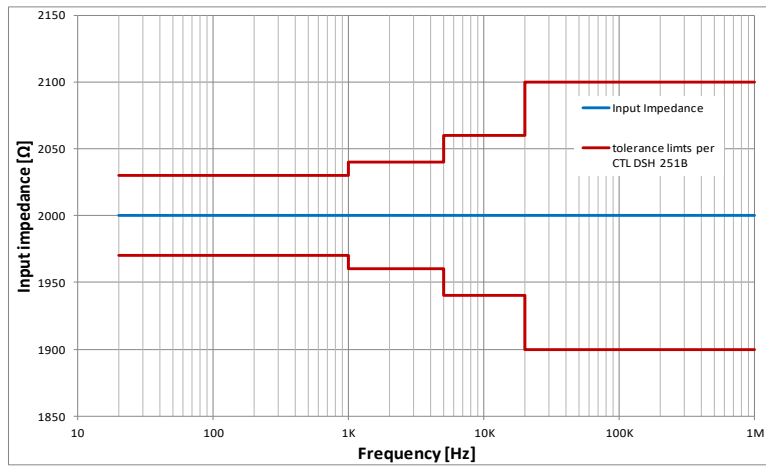

Figure A13. Input Impedance vs Frequency

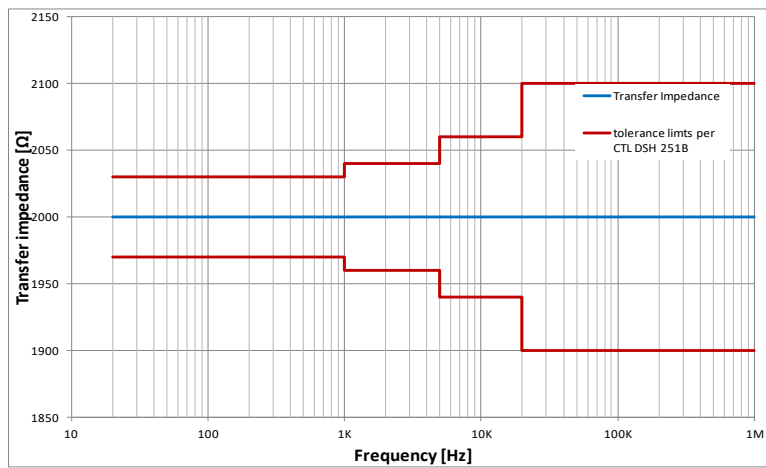

Figure A14. Transfer Impedance vs Frequency

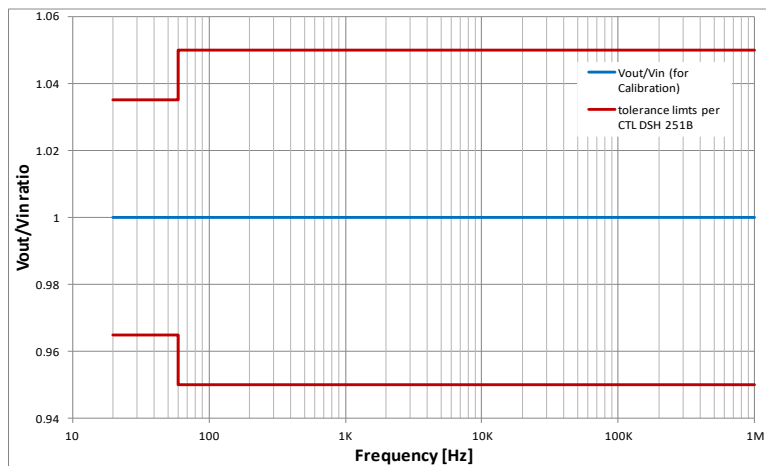

Figure A15. Vout/Vin Ratio vs Frequency

Tolerance comparison for LCB Configuration 6

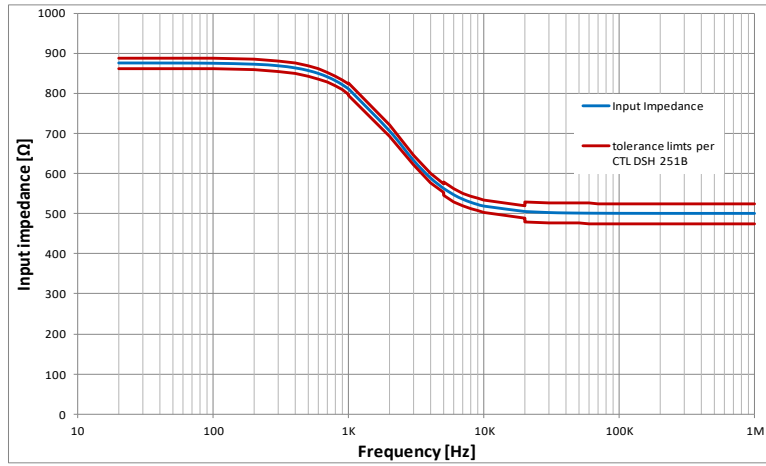

Figure A16. Input Impedance vs Frequency

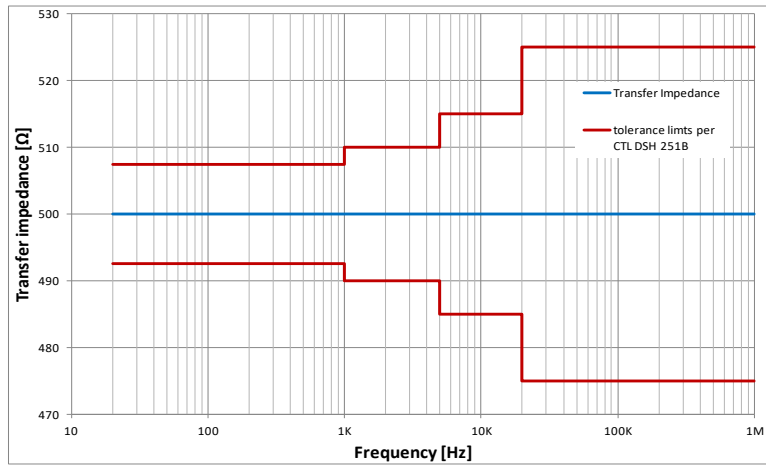

Figure A17. Transfer Impedance vs Frequency

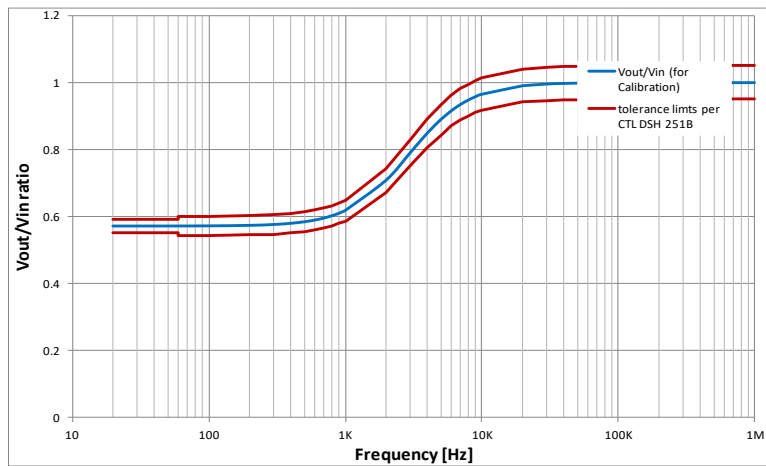

Figure A18. Vout/Vin Ratio vs. Frequency

Tolerance comparison for LCB Configuration UL

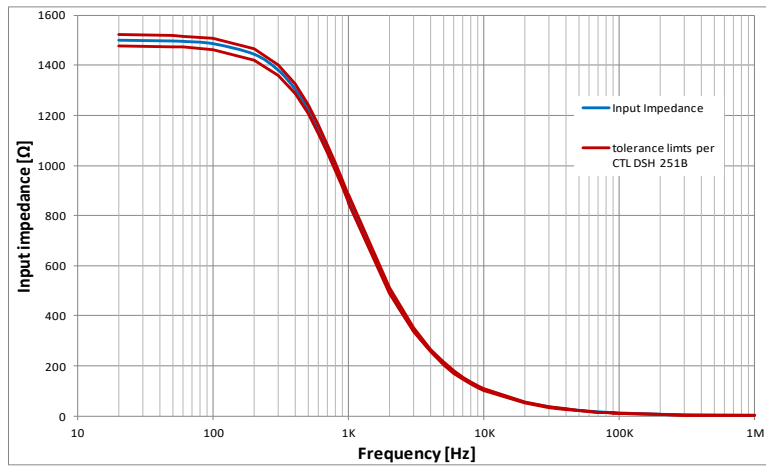

Figure A19. Input Impedance vs Frequency

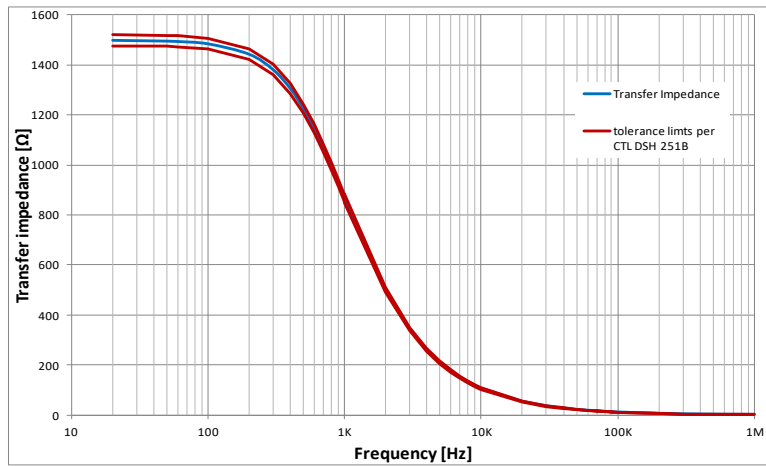

Figure A20. Transfer Impedance vs Frequency

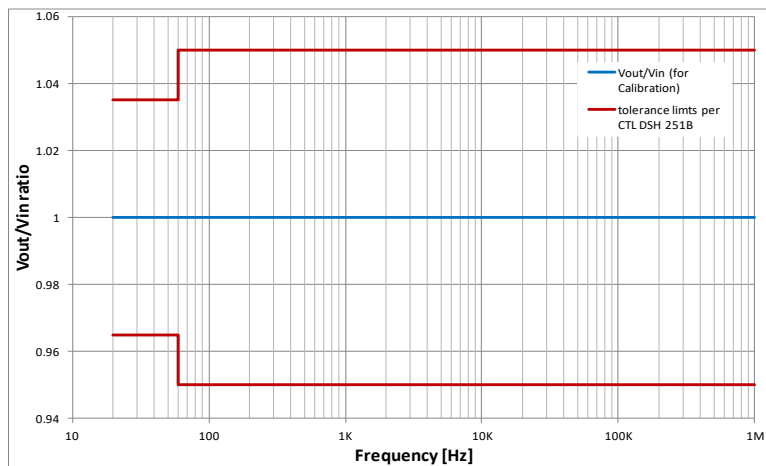

Figure A21. Vout/Vin Ratio vs Frequency